



OUTBACK MOTORTEK

Honda CRF 450L/RL

QUICK ASSEMBLY GUIDE | SKID PLATE

FOR FULL INSTALLATION INSTRUCTIONS, PLEASE WATCH [THIS VIDEO](#).

Tools Required

- 10mm Wrench/Spanner
- Ratchet + Extension
- 4mm Allen Socket
- 5mm Allen Socket
- 8mm Hex Socket
- 10mm Hex Socket
- Blue Loctite (recommended)

Number	QTY	Specifications	Torque (NM)
<u>1</u>	2	M8 x 35mm Hex Bolt	23
<u>2</u>	2	M8 x 16mm Hex Bolt	23
<u>3</u>	3	M8 x 16mm Tapered Allen Bolt	23
<u>4</u>	4	M6 x 20mm Tapered Allen Bolt	10
<u>5</u>	2	M6 x 16mm Hex Bolt	10
<u>6</u>	4	M8 Washer	-
<u>7</u>	6	M6 Washer	-
<u>8</u>	4	M6 Nyloc Nut	-

* PLEASE REFER TO THE OWNER'S (OR SERVICE) MANUAL FOR OEM TORQUE SPECIFICATIONS.*

STEP 1:

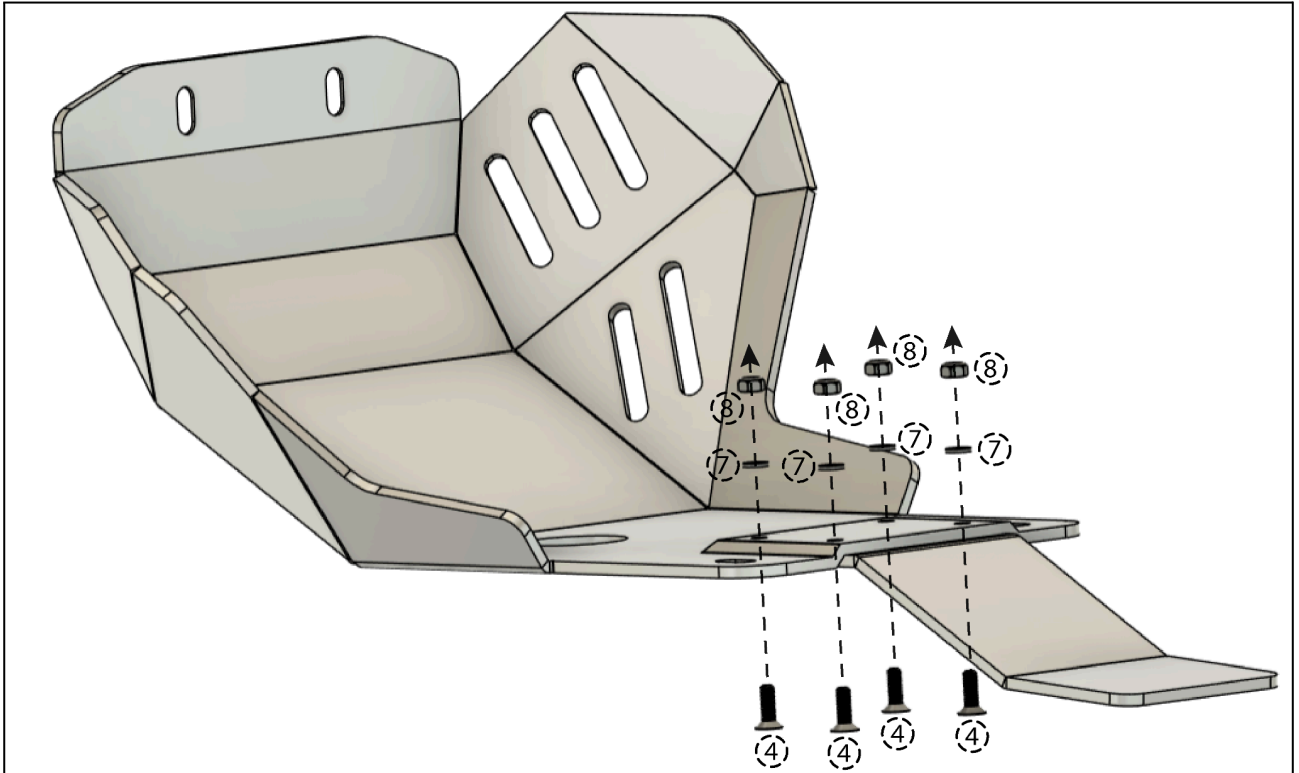

STEP 2:

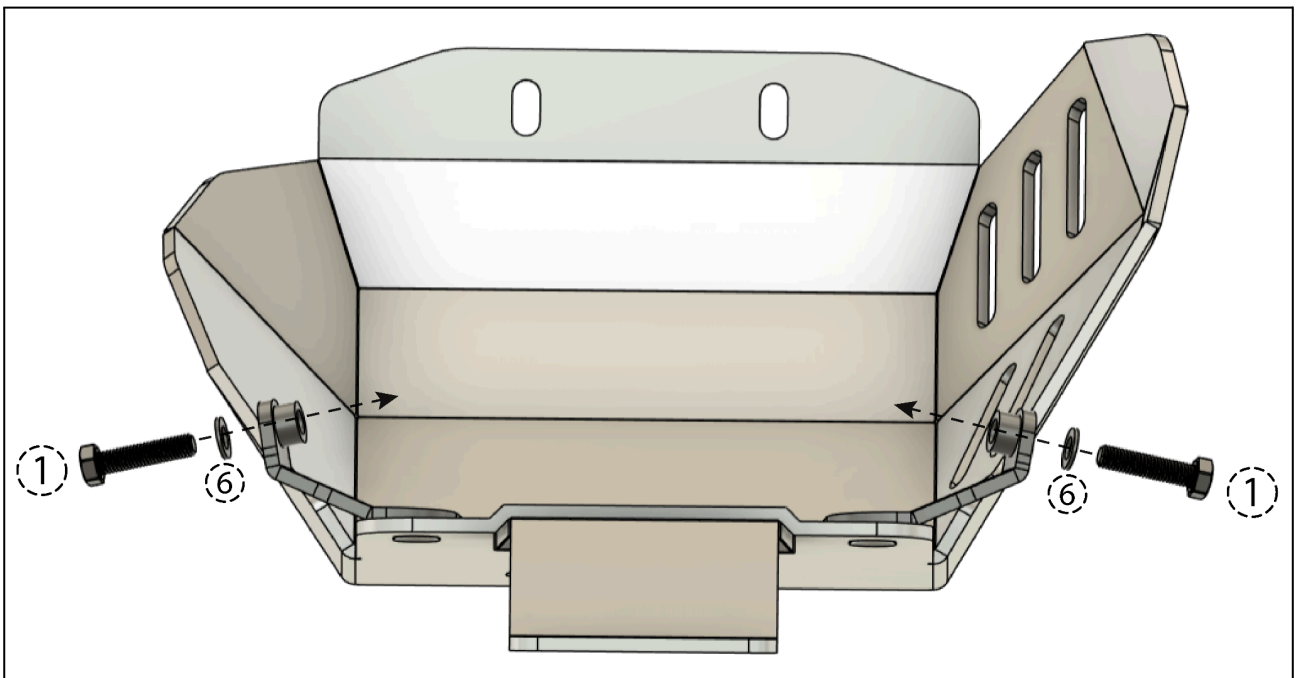

* PLEASE REFER TO THE OWNER'S (OR SERVICE) MANUAL FOR OEM TORQUE SPECIFICATIONS.*

STEP 3:

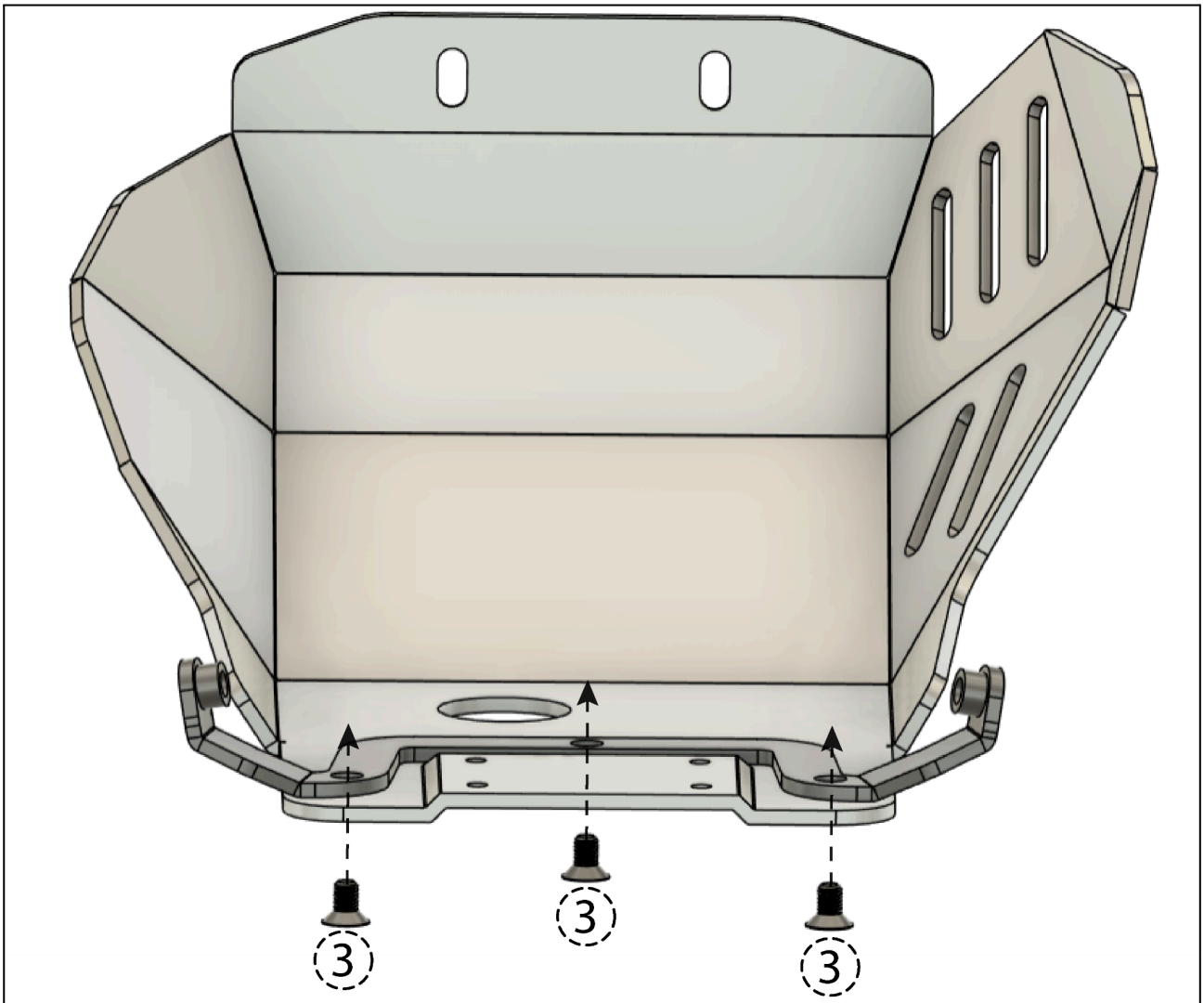

* PLEASE REFER TO THE OWNER'S (OR SERVICE) MANUAL FOR OEM TORQUE SPECIFICATIONS.*

STEP 4:

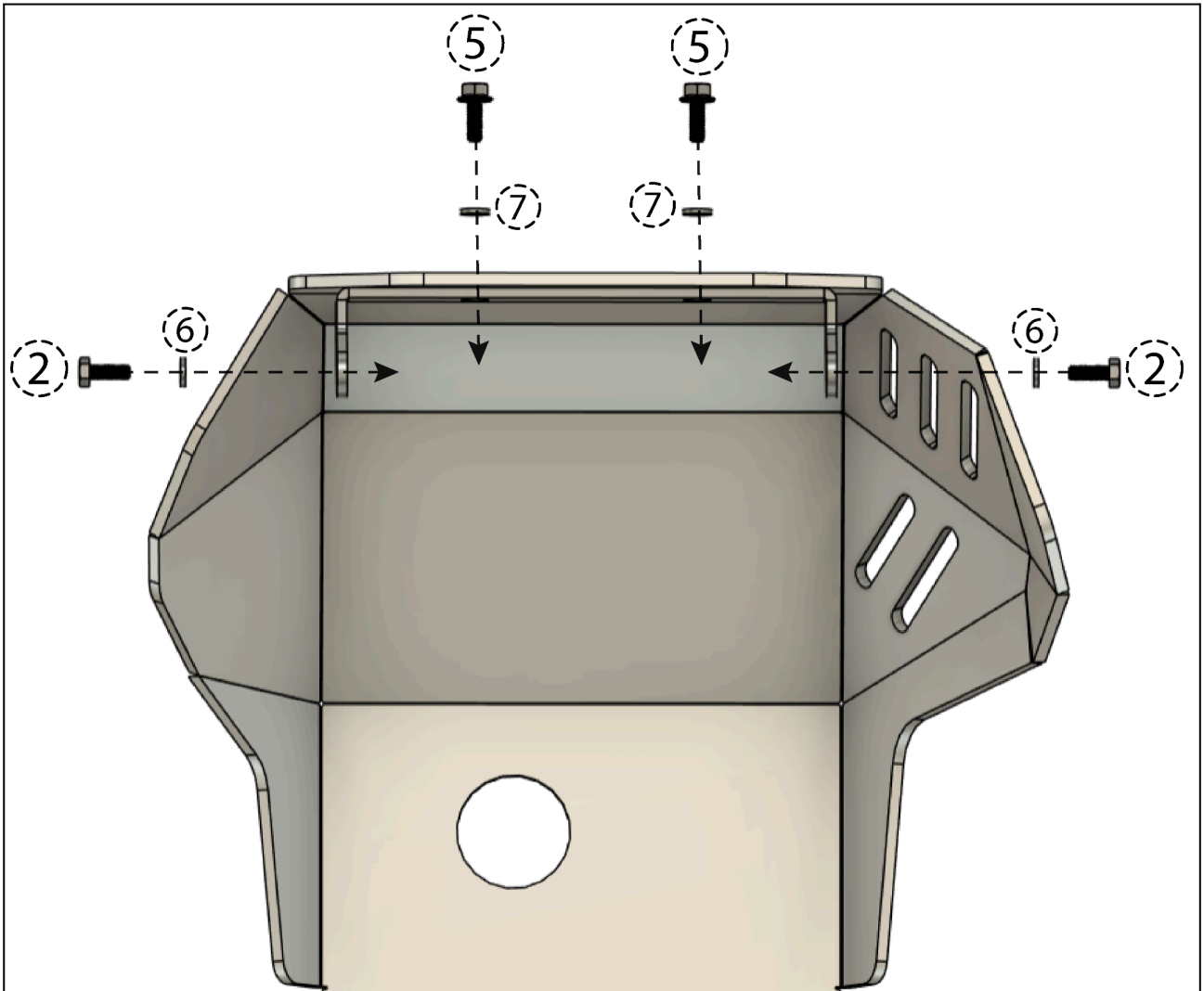

* PLEASE REFER TO THE OWNER'S (OR SERVICE) MANUAL FOR OEM TORQUE SPECIFICATIONS.*